

- NOTE:
1. GEARBOX RATIOS : 80, 120, 140, 160, 210 & 280:1
 2. GEARBOX BASEPLATE: F14/FA14, F16/FA16 & F25/FA25
 3. DIMENSIONS WITH "*" INDICATE COVER REMOVAL ALLOWANCE
 4. THE INTERFACE PROVIDED FOR MOUNTING THE ACTUATOR OR SECOND STAGE GEARBOX ONTO THE VALVE SHOULD CONFORM TO GOOD ENGINEERING PRACTICES, ENSURING ADEQUATELY TOLERANCED LIMITS FOR PARALLELISM, PERPENDICULARITY AND CONCENTRICITY.
 5. ROTORK CANNOT BE HELD LIABLE FOR DAMAGE TO OUR EQUIPMENT CAUSED BY EXCESSIVE LOADING FROM COVER TUBES, HANDWHEEL AND HAND LEVER.

PARAMETER	VALUE	DESCRIPTION
DRAWING TYPE	A	INSTALLATION DRAWING
ACTUATOR	1	CK(R)30/CK60
GEARBOX1	W5	IW5
GEARBOX2	RL	LOW RATIO
CENTORNIK / TERMINAL	S	SET/3 COND
MECHANISM / MOTOR	0	STD. MECH/LARGE MOT.
HANDWHEEL / REAR / FRONT	0	STD.H.W./STD.REAR./STD.FRNT.
ORIENTATION	0	STD.ORIENT.

	Drawn	TAMIL	28-06-17	Title DIMENSIONAL DRAWING, CK30/60 & CKR30/60, IW5, LOW RATIO, 3 CONDUIT ENTRIES, LARGE MOTOR, STANDARD ORIENTATION	A4	Doc Number A1W5RLS000X	Ver No 1	Scale NTS	Sheet No 1 of 2
	Checked	BHARAT	28-06-17						

CONDUIT ENTRY HOLE		
Hole	Metric	NPT
A	M32	1 1/4"
B	M25	3/4"
C	M20	3/4"

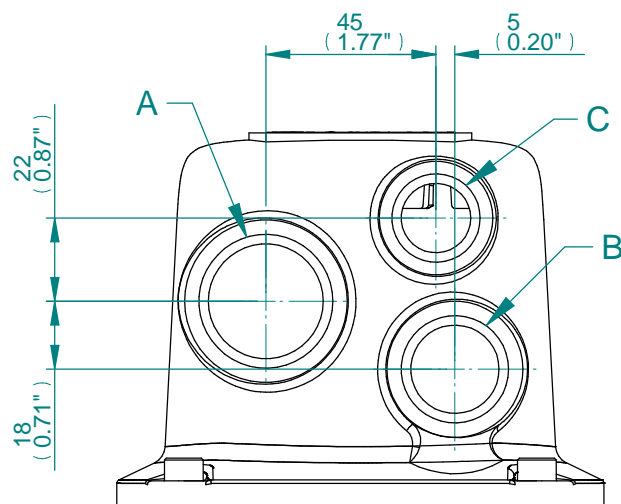

CONDUIT ENTRIES

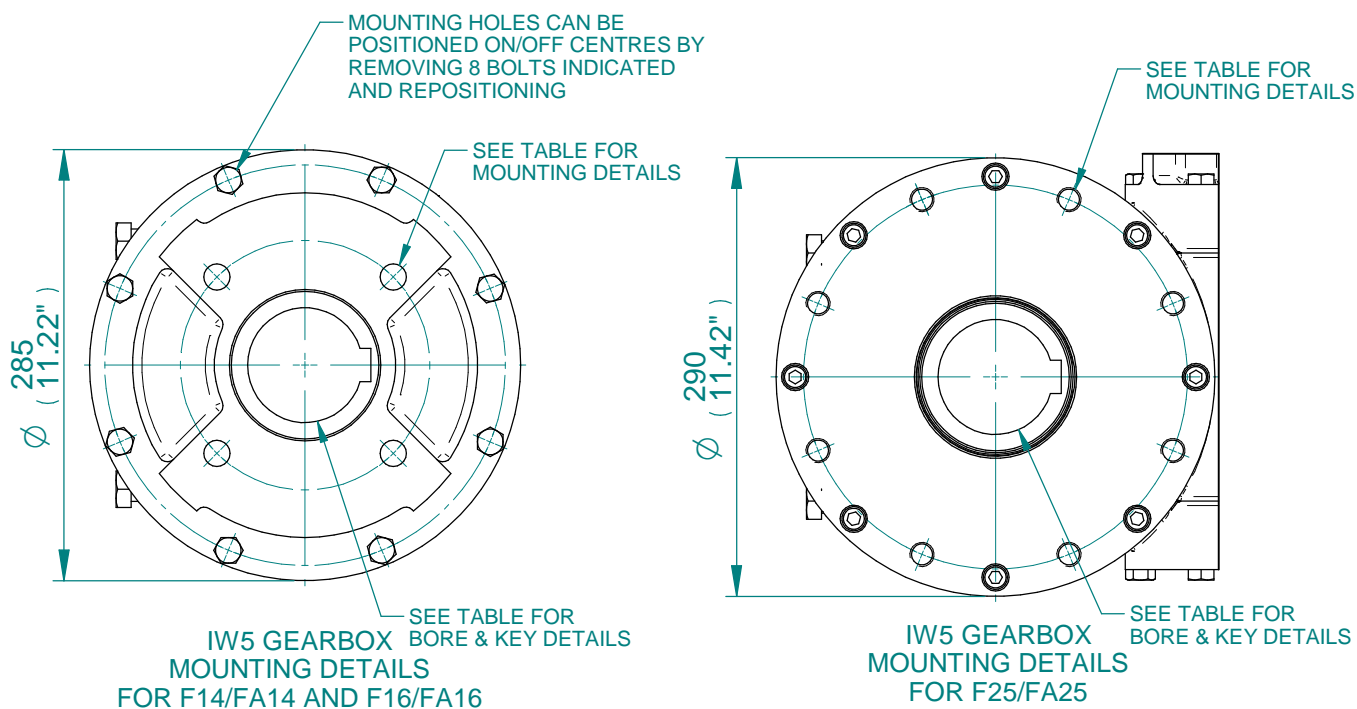

IW5 GEARBOX MOUNTING DETAILS FOR F14/FA14 AND F16/FA16

IW5 GEARBOX MOUNTING DETAILS FOR F25/FA25

BASEPLATE	X	Y	Z
STANDARD THICKNESS	65	110	128
FILLED THICKNESS	75	120	138
WAFER THICKNESS	101	146	164

STD	MAX BORE SQ KEY		MAX BORE RECTANGULAR KEY	
	BORE	KEY	BORE	KEY
BS4235	-	-	76.0	22X14
BS46	2.75"	3/4" SQ	3.00"	3/4"X1/2"
ANSI B17.1	2.75"	5/8" SQ	3.00"	3/4"X1/2"

BASEPLATE DETAILS		
TYPE	BASEPLATE	HOLE DETAILS (45° OFF CENTRES)
ISO F14	STANDARD	4 HOLES M16X16 (0.63") DEEP ON Ø140.0 (Ø5.51") P.C.
FA14		4 HOLES 5/8"UNCx16 (0.63") DEEP ON Ø139.7 (Ø5.50") P.C.
ISO F16		4 HOLES M20X16 (0.63") DEEP ON Ø165.0 (Ø6.50") P.C.
FA16		4 HOLES 3/4"UNCx16 (0.63") DEEP ON Ø165.0 (Ø6.50") P.C.
TYPE	BASEPLATE	HOLE DETAILS (22.5° OFF CENTRES)
ISO F25	FILLED AND WAFER	8 HOLES M16X16 (0.63") DEEP ON Ø254.0 (Ø10.00") P.C.
FA25		8 HOLES 5/8"UNCx16 (0.63") DEEP ON Ø254.0 (Ø10.00") P.C.



Drawn	TAMIL	28-06-17
Checked	BHARAT	28-06-17
Approved	JOSE	28-06-17

Title DIMENSIONAL DRAWING, CK30/60 & CKR30/60, IW5, LOW RATIO, 3 CONDUIT ENTRIES, LARGE MOTOR, STANDARD ORIENTATION

This drawing and the information it contains are property of Rotork Controls Limited, and they will not be reproduced or disclosed, in whole or in part, without the prior written consent of Rotork.

A4	Doc Number	Ver No	Scale	Sheet No
	A1W5RLS000X	1	NTS	2 of 2