

- NOTE:
1. GEARBOX RATIOS : 80, 120, 140, 160, 210 & 280:1
 2. GEARBOX BASEPLATE: F12/FA12, F14/FA14 & F16/FA16.
 3. DIMENSIONS WITH "*" INDICATE COVER REMOVAL ALLOWANCE.
 4. THE INTERFACE PROVIDED FOR MOUNTING THE ACTUATOR OR SECOND STAGE GEARBOX ONTO THE VALVE SHOULD CONFORM TO GOOD ENGINEERING PRACTICES, ENSURING ADEQUATELY TOLERANCED LIMITS FOR PARALLELISM, PERPENDICULARITY AND CONCENTRICITY.
 5. ROTORK CANNOT BE HELD LIABLE FOR DAMAGE TO OUR EQUIPMENT CAUSED BY EXCESSIVE LOADING FROM COVER TUBES, HANDWHEEL AND HAND LEVER.

PARAMETER	VALUE	DESCRIPTION
DRAWING TYPE	A	INSTALLATION DRAWING
ACTUATOR	1	CK(R)30/60
GEARBOX1	W4	IW4
GEARBOX2	RL	LOW RATIO
CENTRONIK / TERMINAL	S	SET/3 COND
MECHANISM / MOTOR	S	STD.MECH/SMALL MOT.
HANDWHEEL / REAR / FRONT	0	STD.H.W./STD.REAR./STD.FRNT.
ORIENTATION	0	STD.ORIENT.

CK range	Drawn	JB	14-05-18
	Checked	FT	14-05-18
	Approved	FT	14-05-18

Title	DIMENSIONAL DRAWING, CK30/60 & CKR30/60, IW4 LOW RATIO, 3 CONDUIT ENTRIES, SMALL MOTOR, STANDARD ORIENTATION
--------------	--

A4	Doc Number	Ver No	Scale	Sheet No
	A1W4RLSS00X	1	NTS	1 of 2

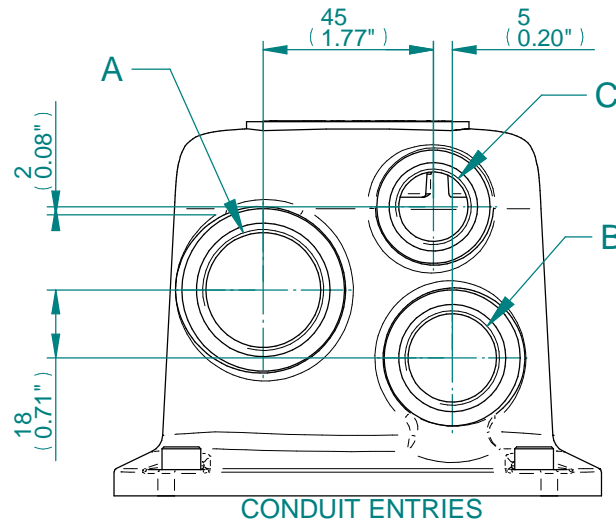

CONDUIT ENTRY HOLE		
Hole	Metric	NPT
A	M32	1 1/4"
B	M25	3/4"
C	M20	3/4"

MOUNTING HOLES CAN BE POSITIONED ON/OFF CENTRES BY REMOVING 8 BOLTS INDICATED AND REPOSITIONING

SEE TABLE FOR MOUNTING DETAILS

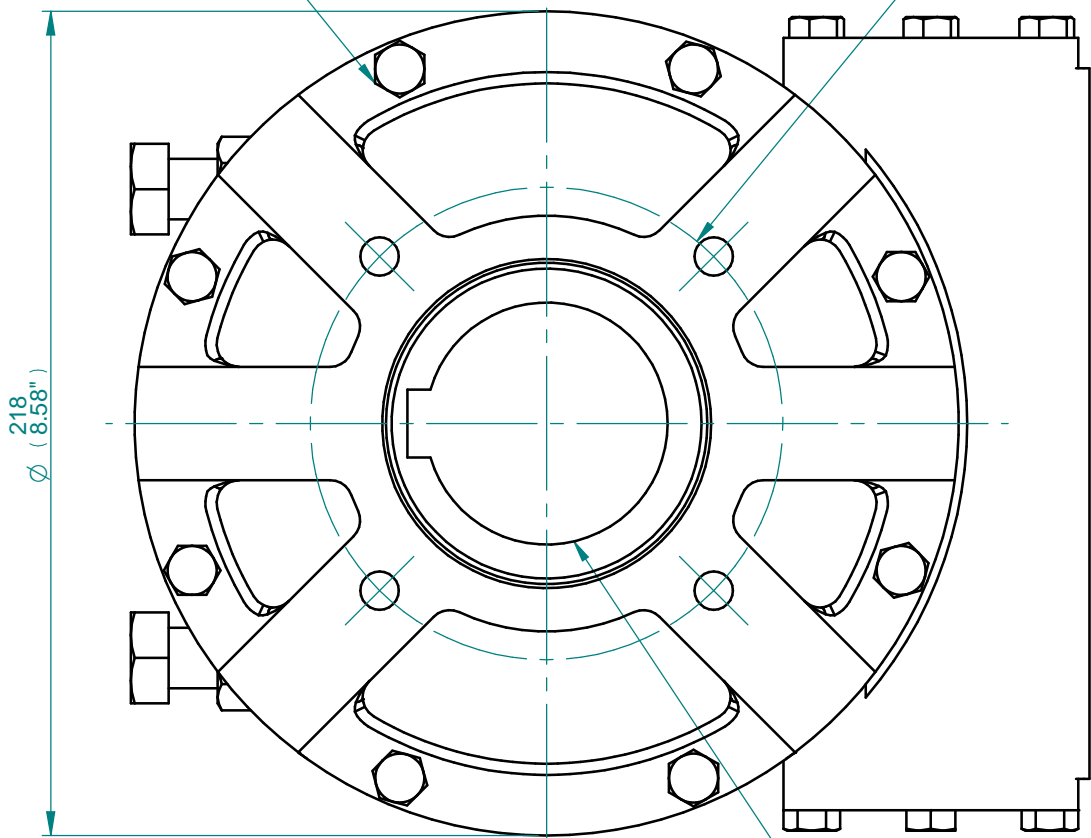

IW4 GEARBOX MOUNTING DETAILS

SEE TABLE FOR BORE & KEY DETAILS

BASEPLATE	X	Y	Z
STANDARD THICKNESS	50	85	104
FILLED THICKNESS	-	-	-
WAFER THICKNESS	75	110	129

STD	MAX BORE SQ KEY		MAX BORE RECTANGULAR KEY	
	BORE	KEY	BORE	KEY
BS4235	-	-	64.0	18X11
BS46	2.25"	5/8" SQ	2.50"	5/8"X7/16"
ANSI B17.1	2.25"	1/2" SQ	2.50"	5/8"X7/16"

BASEPLATE DETAILS		
TYPE	BASEPLATE	HOLE DETAILS (45° OFF CENTRES)
ISO F12	STANDARD	4 HOLES M12 x 16 (0.63") DEEP ON Ø125 (Ø4.92") P.C.
FA12		4x 1/2"UNC x 16 (0.63") DEEP ON Ø125.7 (Ø4.95") P.C.
ISO F14		4 HOLES M16X16 (0.63") DEEP ON Ø140.0 (Ø5.51") P.C.
FA14		4 HOLES 5/8"UNCx16 (0.63") DEEP ON Ø139.7 (Ø5.50") P.C.
ISO F16	WAFER	4 HOLES M20X30 (1.18") DEEP ON Ø165.0 (Ø6.50") P.C.
FA16		4 HOLES 3/4"UNCx30 (1.18") DEEP ON Ø165.0 (Ø6.50") P.C.



Drawn	JB	14-05-18
Checked	FT	14-05-18
Approved	FT	14-05-18

Title DIMENSIONAL DRAWING, CK30/60 & CKR30/60, IW4 LOW RATIO , 3 CONDUIT ENTRIES, SMALL MOTOR, STANDARD ORIENTATION

A4	Doc Number	Ver No	Scale	Sheet No
	A1W4RLSS00X	1	NTS	2 of 2

This drawing and the information it contains are property of Rotork Controls Limited, and they will not be reproduced or disclosed, in whole or in part, without the prior written consent of Rotork.