

FAIRCHILD MODEL 200 PNEUMATIC VOLUME BOOSTER

Installation, Operation and Maintenance Instructions

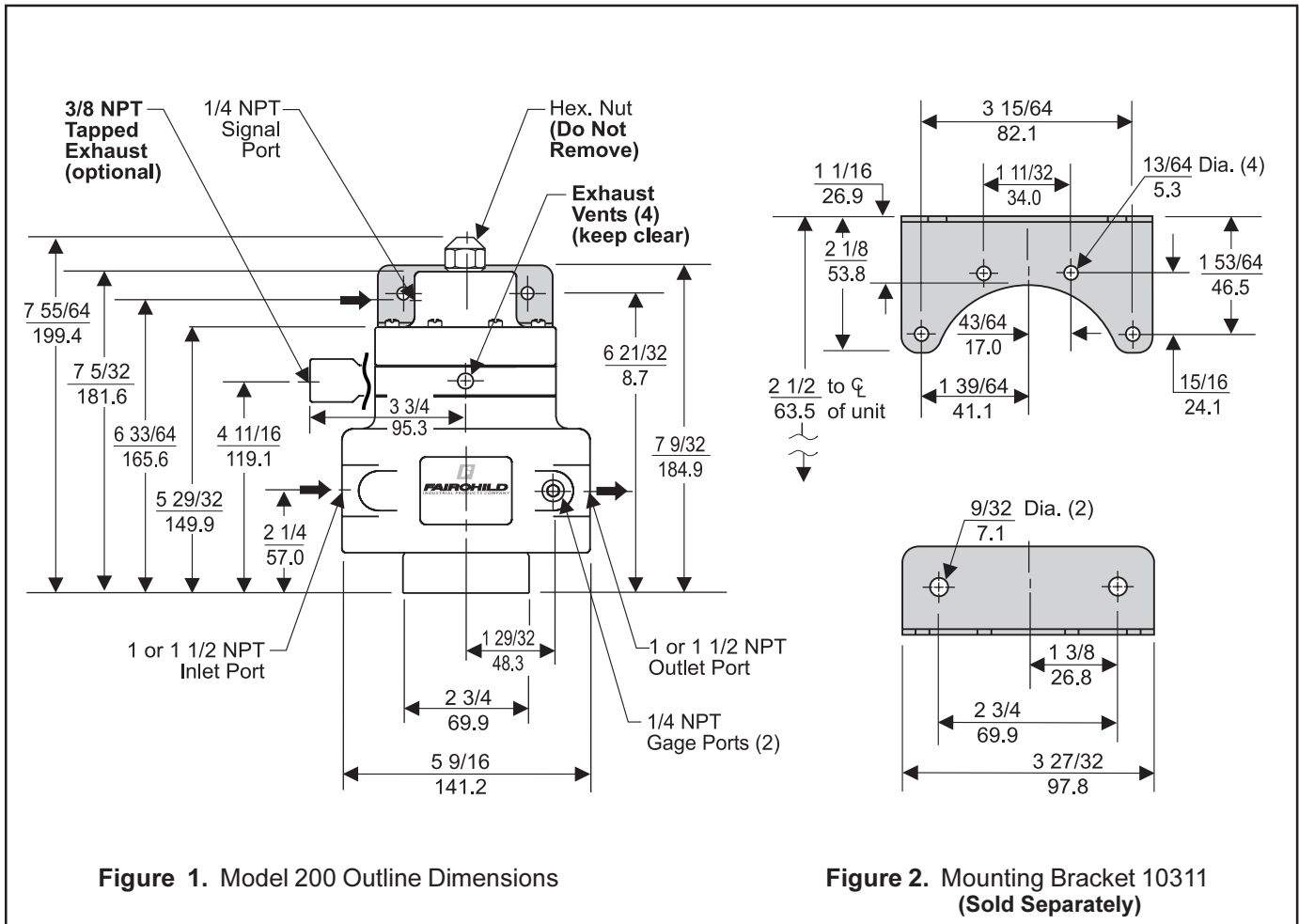

INSTALLATION

You can mount the Model 200 in any position without affecting its operation. Use the Mounting Bracket, 10311, to mount the booster to any flat surface. For more information, see Figure 2.

Arrows indicate the Inlet and Outlet ports on the booster. Tighten all connections securely. Avoid undersized fittings that will limit the flow through the booster. For more information, see Figure 1.

Clean all pipelines to remove dirt and scale before installation.

Apply a minimum amount of pipe compound to the male threads of the fitting only. **Do Not use teflon tape as a sealant.** Start with the third thread back and work away from the end of the fitting to avoid contaminating the booster. Install the booster in the air line.

NOTE:

Oil free air must be applied to the booster. Use a filter to remove dirt and entrained liquid in the air line ahead of the booster. If an air line lubricator is used, it MUST be located downstream of the booster to avoid interference with performance.

OUTLINE DIMENSIONS

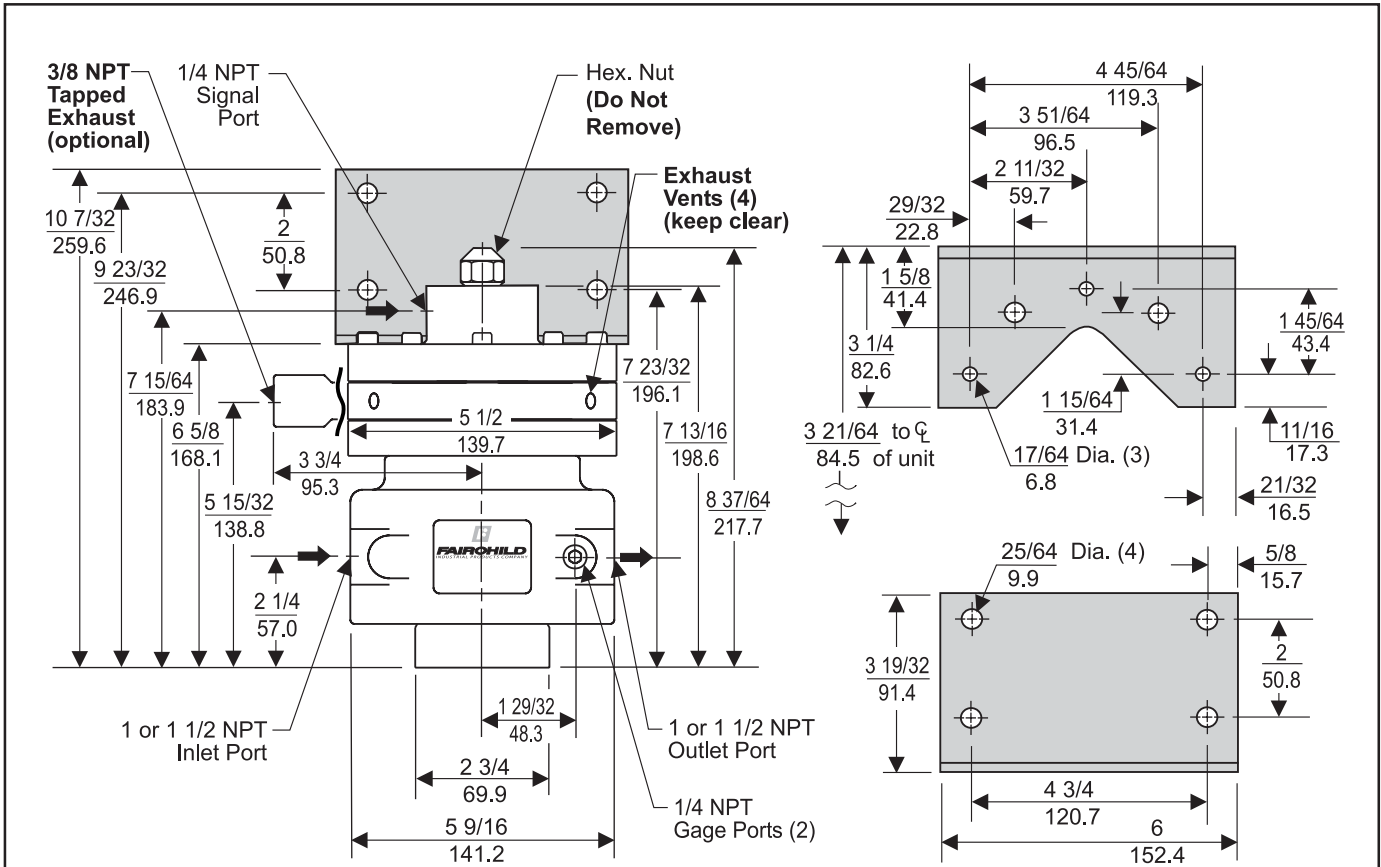

Figure 3. Model 200 Outline Dimensions shown with Increased Sensitivity Option (L)

Figure 4. Mounting Bracket EB-19682-1 (Sold Separately)

INSTALLATION

If you have the Model 200 with Increased Sensitivity Option (L), use the Mounting Bracket, 19682-1, to mount the booster to any flat surface. For more information, see Figure 4.

For more installation information, see page 1.

OPERATION

The Model 200 reproduces a pneumatic signal in a 1:1 ratio. Apply pressure to the signal chamber until the required downstream pressure is reached.

This booster is ideally suited for systems that require input isolation or increased forward flow capacity. For more information, see Figure 1 and Figure 3.

To clean the Model 200, use the following steps:

1. Shut off system pressure to the booster to prevent air from escaping. It is not necessary to remove the booster from the air line.
2. Remove the six screws from the bottom of unit. For more information, see Figure 5.
3. Remove the Valve Assembly. For more information, see Figure 5.
4. Wash the Valve Assembly with a solvent. Exercise care to prevent damage to diaphragms and valve facings. **Avoid solvents such as acetone, carbon tetrachloride and trichlorethylene.**
5. Replace the assembly carefully. Ensure that the Exhaust Vents in the Spacer Ring are clear. For more information, see Figure 5.

Troubleshooting

Table 1. Troubleshooting		
Problem	Source	Solution
When the signal is off, the valve does not close.	<ul style="list-style-type: none"> • Valve seat • Diaphragm Assembly 	<ul style="list-style-type: none"> • Check the valve seat. • Ensure that the diaphragm is not punctured.
Leakage / High Bleed	<ul style="list-style-type: none"> • Bonnet or Retainer Screws • Relief Valve • Supply Valve • Supply Seat • Diaphragm Assemblies 	<ul style="list-style-type: none"> • Tighten the Bonnet or Retainer Screws • If contaminated, clean the source. • If damaged, install the service kit.

NOTE: If the standard maintenance procedure does not correct the problem, install the appropriate service kit.

Standard/Tapped Exhaust

- 12151-1
- 12151-4 (Increased Sensitivity)
Non-relieving
- 12151-2
- 12151-5 (Increased Sensitivity)
Viton
- 12151-3
- 12151-6 (Increased Sensitivity)

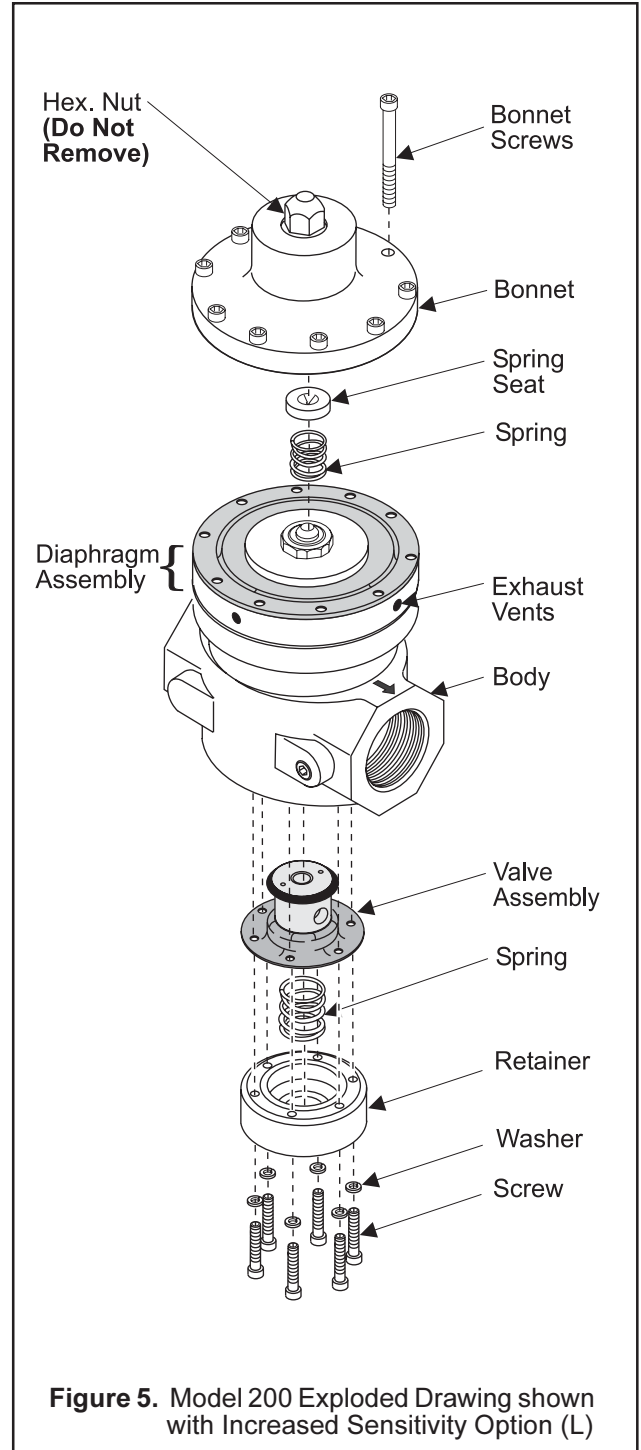

Figure 5. Model 200 Exploded Drawing shown with Increased Sensitivity Option (L)

LEGAL NOTICE:

The information set forth in the foregoing Installation, Operation and Maintenance Instructions shall not be modified or amended in any respect without prior written consent of Fairchild Industrial Products Company. In addition, the information set forth herein shall be furnished with each product sold incorporating Fairchild's unit as a component thereof.