

Model 200XLR Pneumatic Volume Booster



C
Model
200
XLR

Features

- The Model 200XLR Pneumatic Volume Booster produces a pneumatic signal in a 1:1 ratio. It is ideally suited for systems that require input isolation or increased forward and exhaust flow capacities.
- Control sensitivity to 1" water column variation
- Large supply and Exhaust Valves provide high forward and exhaust flows
- An Aspirator Tube minimizes downstream pressure droop under flow conditions.
- A separate Control Chamber isolates the diaphragm from the main flow to eliminate hunting and buzzing
- Optional Increased Sensitivity configuration with larger Control Diaphragm for more precision control at low setpoints.

Operating Principles

When signal pressure on the top of the signal Diaphragm creates a downward force on the Diaphragm Assembly, the Supply Valve opens. Output pressure flows through the Outlet Port and the Aspirator Tube to the Control Chamber to create an upward force on the bottom of the Control Diaphragm. When the setpoint is reached, the downward force of the signal pressure that acts on the top of the Signal Diaphragm balances with the upward force of the output pressure that acts on the bottom of the Control Diaphragm.

When the output pressure increases above the signal pressure, the Diaphragm Assembly moves upward to close the Supply Valve and open the Exhaust Valve. Excess output pressure exhausts through the Exhaust Port until it reaches the setpoint.

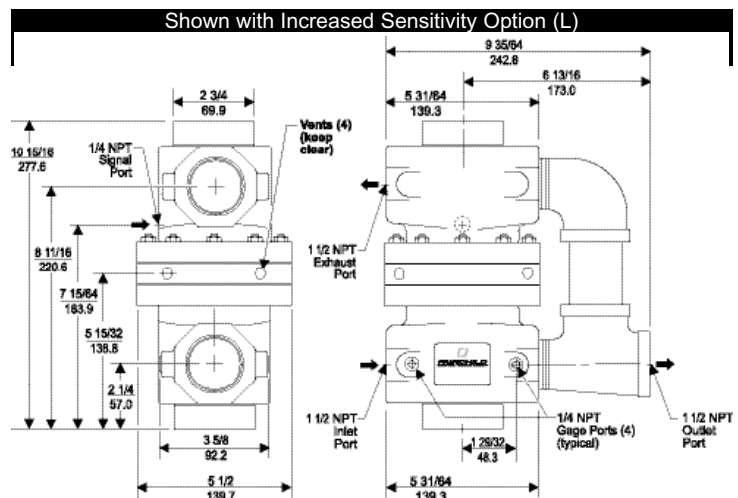
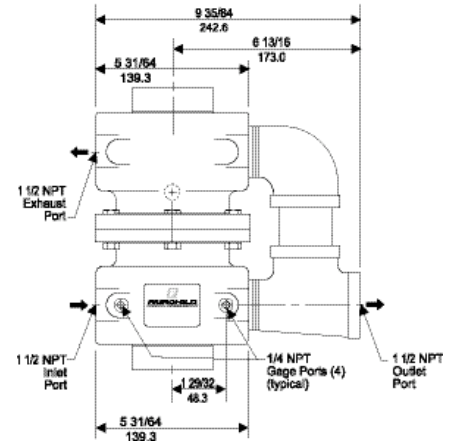
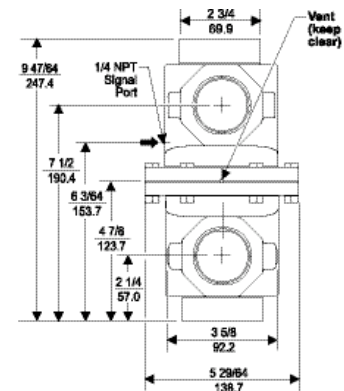
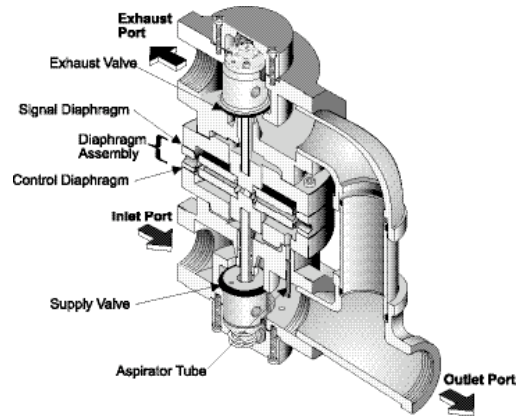

Specifications

Flow Capacity (SCFM)

In excess of 1500 (2550 m³/hr) @ 100 psig, [7.0 BAR], (700 kPa) supply and 20 psig, [1.5 BAR], (1500 kPa) setpoint

Exhaust Capacity (SCFM)

325 (552.5 m³/hr) where downstream pressure is 5 psig, [.35 BAR], (35 kPa) above 20 psig, [1.5 BAR], (150 kPa) setpoint

Supply Pressure

250 psig, [17.0 BAR], (1700 kPa) Maximum

Supply Pressure Effect

Less than 0.5 psig, [.03 BAR], (3.4 kPa) for 100 psig, [7.0 BAR], (700 kPa) change in supply pressure

Signal or Output Pressure

150 psig, [10.0 BAR], (1000 kPa) Maximum

Sensitivity

1" (2.54 cm) Water Column

Ambient Temperature

-40°F to +200° F, (-40°C to +93° C)

Materials of Construction

Body and Housing Die Cast Aluminum
 Trim Stainless Steel, Brass, Aluminum,
 and Zinc Plated Steel
 Diaphragms Nitrile or Dacron

Catalog Information

Catalog Number	2001	<input type="checkbox"/>	XLR	<input type="checkbox"/>
Pipe Size	1 1/2" NPT	<input type="checkbox"/>		<input type="checkbox"/>
		12		
Options	Fluorocarbon (Viton) Elastomers			<input type="checkbox"/>
	Increased Sensitivity		L	<input type="checkbox"/>
	(for more precision control at low setpoints)			

Installation

For installation instructions, refer to the *Fairchild Model 200XLR Pneumatic Volume Booster Installation, Operation and Maintenance Instructions, IS-20200XLR.*

