

FAIRCHILD MODEL 20 PNEUMATIC HIGH CAPACITY VOLUME BOOSTER Installation, Operation and Maintenance Instructions

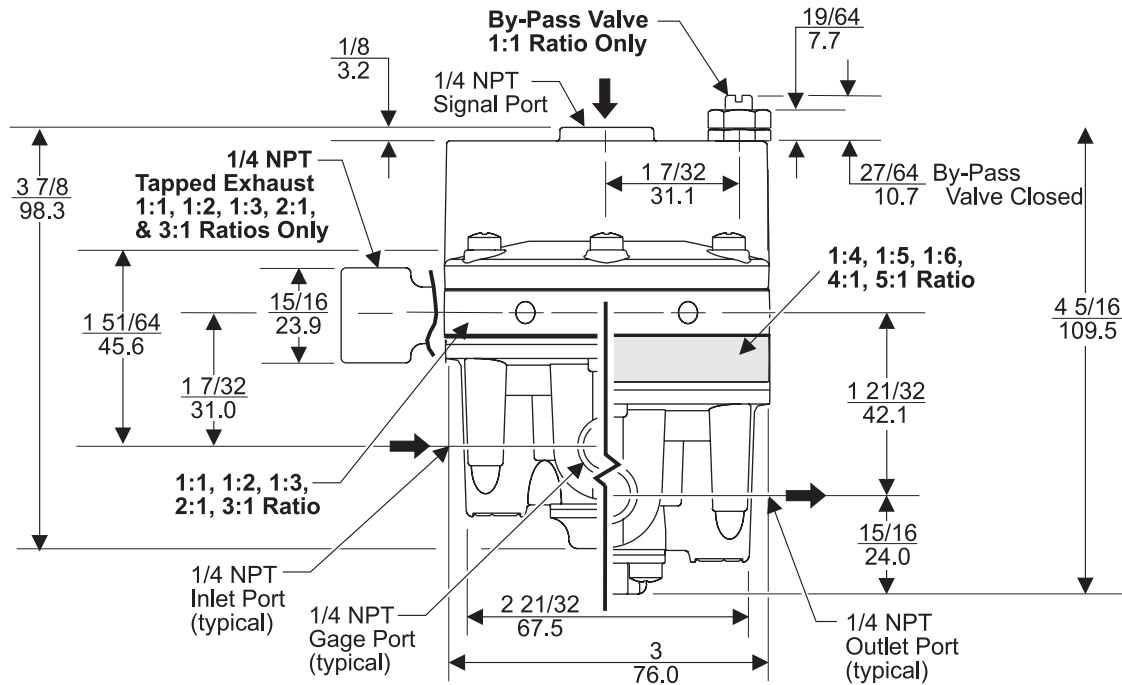

Figure 1. Model 20 Outline Dimensions.

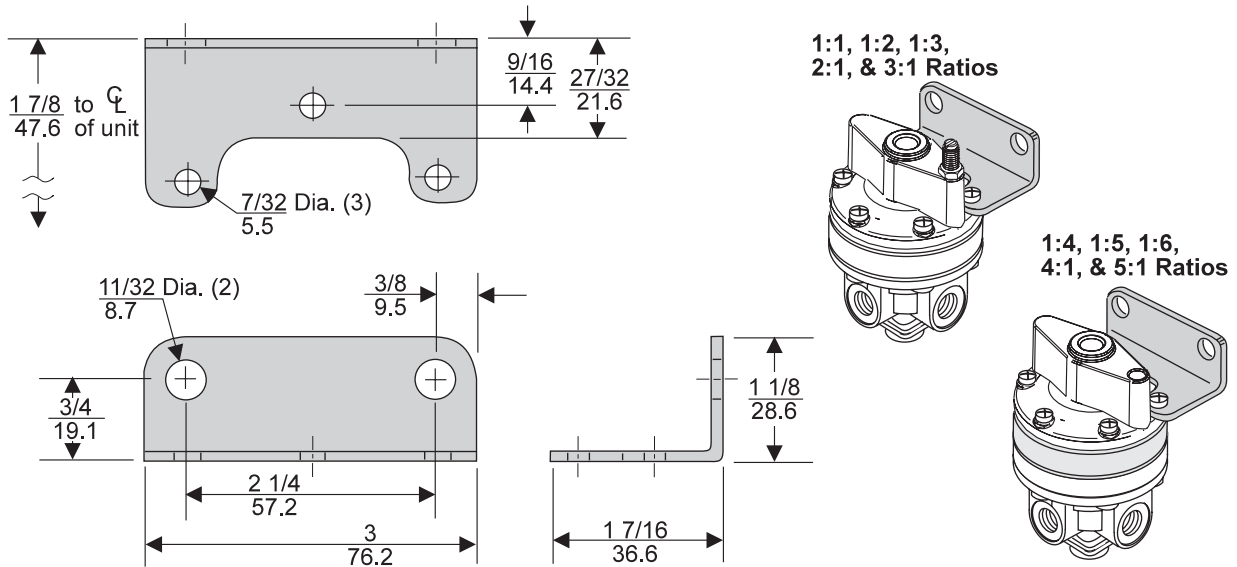

Figure 2. Mounting Bracket 09921. (Sold Separately)

INSTALLATION

The Model 20 can be mounted in any position without affecting its operation. It can be mounted to a flat surface using Mounting Bracket 09921. For more information, see Figure 1. "Model 20 Outline Dimensions" above.

Clean all pipelines to remove dirt and scale before installation.

Apply a minimum amount of pipe compound to the male threads of the fitting only. **Do Not use teflon tape as a sealant.** Start with the third thread back and work away from the end of the fitting to avoid the possibility of contaminating the booster. Install the booster in the air line.

The inlet and outlet ports are labeled on the underside of the

INSTALLATION (continued)

booster with the arrows pointing in the direction of the flow. Tighten connections securely. Avoid undersized fittings that will limit the flow through the booster and cause a pressure drop down stream. For more information, see Figure 1. "Outline Drawing" on page 1.

NOTES: Oil free air must be applied to the booster. Use a filter to remove dirt and entrained liquid in the air line ahead of the booster. If an air line lubricator is used, it **MUST** be located downstream of the booster, to avoid interference with booster performance.

OPERATION

The Model 20 reproduces a pneumatic signal in a 1:1 ratio or in multiplying or dividing ratios. ($P_o = P_s \times R$); where P_o is output pressure, P_s is signal pressure, R is ratio.

LEGAL NOTICE:

The information set forth in the foregoing Installation, Operation and Maintenance Instructions shall not be modified or amended in any respect without prior written consent of Fairchild Industrial Products Company. In addition, the information set forth herein shall be furnished with each product sold incorporating Fairchild's unit as a component thereof.

Table 1. Model 20 Components		
Item	Qty.	Description
1	1	Valve
2	6	Screw
3	1	Bonnet
4	See Table 3	Diaphragm Assembly
5	1	Spacer Ring
6	1	Spacer Ring
7 ⁸	1	Washer
8	1	Spring
9	4	Screw
10	1	Seal Plate Assembly
11 ⁷	1	Seal Plate Gasket
12	1	Body Assembly
13 ⁹	1	Seat Assembly (<i>Nitrile</i>)
13 ^{3,6}	1	Seat Assembly (<i>Silicone</i>)
13 ¹⁰	1	Seat Assembly (<i>Viton</i>)
14	1	Screen
15 ⁹	1	Inner Valve Asm. (<i>Nitrile</i>)
15 ^{3,6}	1	Inner Valve Asm. (<i>Silicone</i>)
15 ¹⁰	1	Inner Valve Asm. (<i>Viton</i>)
16	1	Retainer Plate
17	1	Retainer Cap
18	2	Screw

1	For 19513-11I	Service Kit Only. (1:1 Ratio)
2	For 19513-11NI	Service Kit Only. (1:1 Ratio)
3	For 19513-11AI	Service Kit Only. (1:1 Ratio)
4	For 19513-11JI	Service Kit Only. (1:1 Ratio)
5	For 19513-11JNI	Service Kit Only. (1:1 Ratio)
6	For 19513-11A	Service Kit Only. (1:1 Ratio)
7	For All 19513	Service Kits.
8	For 19513	-11, -12, -13, -21, -31, -11A, -11J, -12J, -13J, -21J, -31J, -11JN, -12JN, -13JN, -21JN, -31JN, -11N, -12N, -13N, -21N, -31N Service Kits.
9	For 19513	-11, -12, -13, -21, -31, -11I, -11N, -12N, -13N, -21N, -31N, -11NI Service Kits.
10	For 19513	-11J, -12J, -13J, -21J, -31J, -11JI, -11JN, -12JN, -13JN, -21JN, -31JN, -11JNI Service Kits.

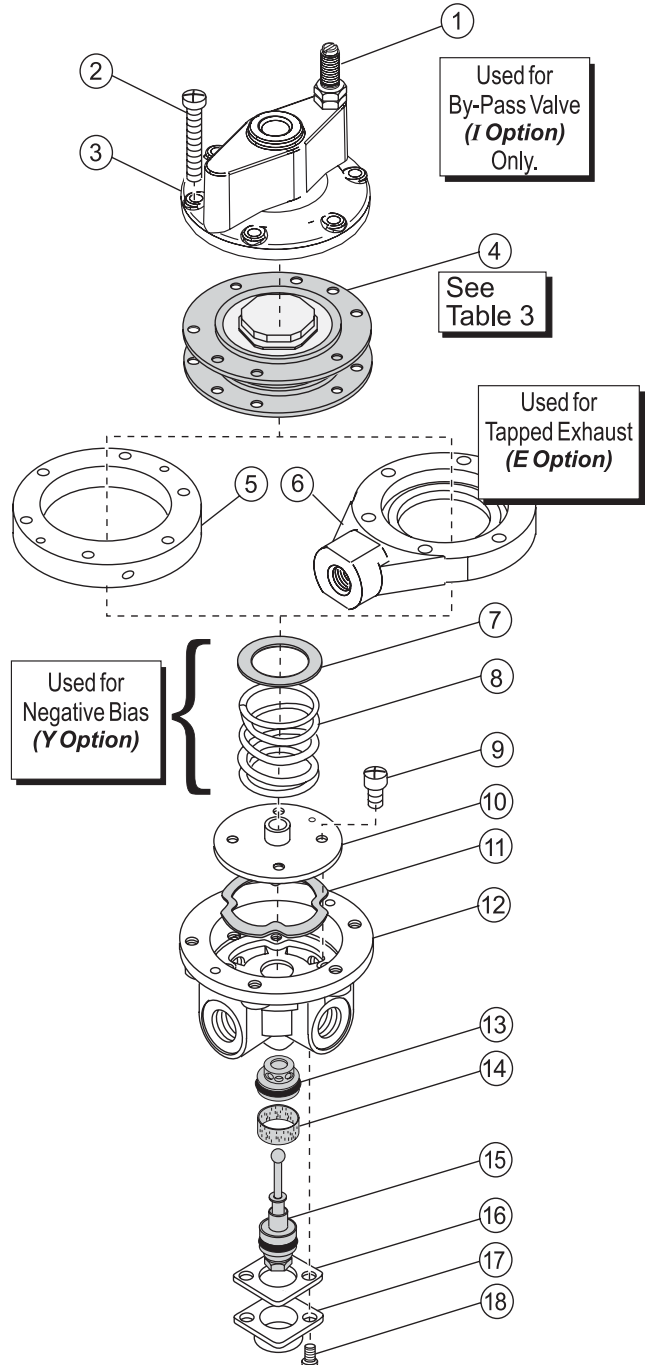

Figure 3. Exploded Drawing for 1:1, 1:2, 1:3, 2:1, & 3:1 Ratios.

MAINTENANCE

To clean the Model 20, use the following procedure:

1. Before disassembly, shut off the valve that is supplying air to the booster. This is to prevent air from escaping. **It is not necessary to remove the booster from the air line.**
2. Remove the two Screws (20) from **Figure 3** or (15) from **Figure 4**.
3. Pull out the Inner Valve Assembly (17) from **Figure 3** or (12) from **Figure 4**. Wash the Seat on the Inner Valve Assembly carefully.

4. Wipe off any particles that may be attached to rubber Seat Assembly (15) from **Figure 3** or (10) from **Figure 4**.
5. Replace the assembly carefully. For more information, see **Figure 3** on page 2 or **Figure 4** on page 3.

NOTES: Avoid such solvents as acetone, carbon tetrachloride and trichlorethylene.

If the standard maintenance procedure does not correct the trouble, install service kit.

Item	Qty.	Description
1	6	Screw
2	1	Bonnet
3 ¹	1	Diaphragm Assembly (Nitrile)
3 ²	1	Diaphragm Assembly (Nitrile)
3 ³	1	Diaphragm Assembly (Nitrile)
3 ⁴	1	Diaphragm Assembly (Nitrile)
3 ⁵	1	Diaphragm Assembly (Nitrile)
3 ⁶	1	Diaphragm Assembly (Viton)
3 ⁷	1	Diaphragm Assembly (Viton)
3 ⁸	1	Diaphragm Assembly (Viton)
3 ⁹	1	Diaphragm Assembly (Viton)
3 ¹⁰	1	Diaphragm Assembly (Viton)
4	1	Spacer Ring
5 ¹¹	1	Gasket
6	4	Screw
7	1	Seal Plate Assembly
8 ¹¹	1	Seal Plate Gasket
9	1	Body Assembly
10 ¹²	1	Seat Assembly (Nitrile)
10 ¹³	1	Seat Assembly (Viton)
11 ¹¹	1	Screen
12 ¹²	1	Inner Valve Assembly (Nitrile)
12 ¹³	1	Inner Valve Assembly (Viton)
13	1	Retainer Plate
14	1	Retainer Cap
15	2	Screw

1	For 19513-14	Service Kit Only. (1:4 Ratio)
2	For 19513-15	Service Kit Only. (1:5 Ratio)
3	For 19513-16	Service Kit Only. (1:6 Ratio)
4	For 19513-41	Service Kit Only. (4:1 Ratio)
5	For 19513-51	Service Kit Only. (5:1 Ratio)
6	For 19513-14J	Service Kit Only. (1:4 Ratio)
7	For 19513-15J	Service Kit Only. (1:5 Ratio)
8	For 19513-16J	Service Kit Only. (1:6 Ratio)
9	For 19513-41J	Service Kit Only. (4:1 Ratio)
10	For 19513-51J	Service Kit Only. (5:1 Ratio)
11	For All 19513	Service Kits.
12	For 19513-14, -15, -16, -41, & -51	Service Kits.
13	For 19513-14J, -15J, -16J, -41J, & -51J	Service Kits.

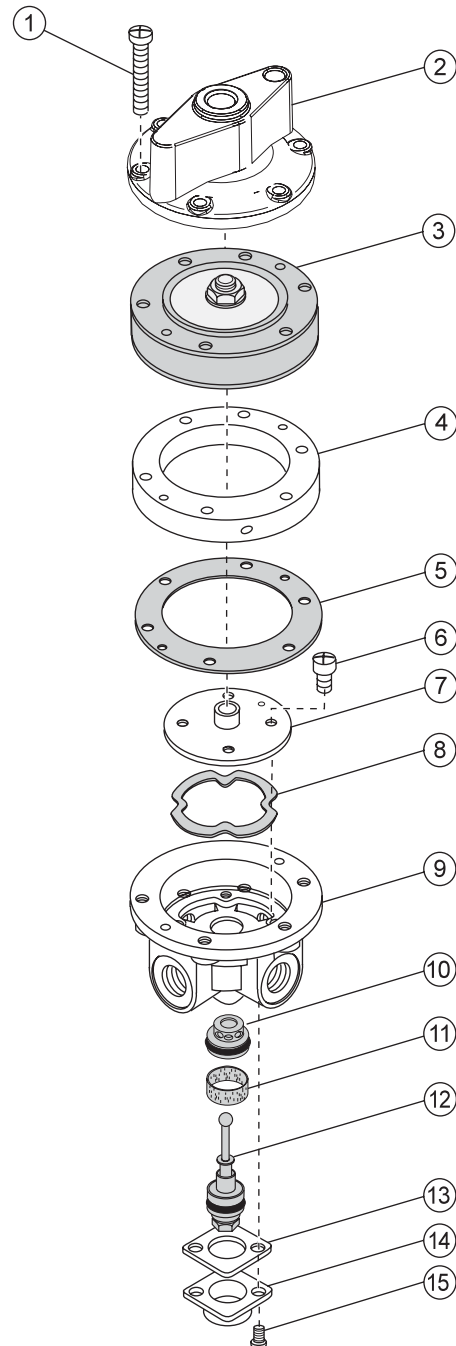

Figure 4. Exploded Drawing for 1:4, 1:5, 1:6, 4:1, & 5:1 Ratios.

MODEL 20 COMPONENTS (continued)

Table 3. Diaphragm Assembly		
Item	Qty.	Description
6 ¹	1	Diaphragm Assembly (Nitrile)
6 ²	1	Diaphragm Assembly (Nitrile)
6 ³	1	Diaphragm Assembly (Nitrile)
6 ⁴	1	Diaphragm Assembly (Nitrile)
6 ⁵	1	Diaphragm Assembly (Nitrile)
6 ⁶	1	Diaphragm Assembly (Silicone)
6 ⁷	1	Diaphragm Assembly (Silicone)
6 ⁸	1	Diaphragm Assembly (Nitrile)
6 ⁹	1	Diaphragm Assembly (Viton)
6 ¹⁰	1	Diaphragm Assembly (Viton)
6 ¹¹	1	Diaphragm Assembly (Viton)
6 ¹²	1	Diaphragm Assembly (Viton)
6 ¹³	1	Diaphragm Assembly (Viton)
6 ¹⁴	1	Diaphragm Assembly (Viton)
6 ¹⁵	1	Diaphragm Assembly (Viton)
6 ¹⁶	1	Diaphragm Assembly (Viton)
6 ¹⁷	1	Diaphragm Assembly (Viton)
6 ¹⁸	1	Diaphragm Assembly (Viton)
6 ¹⁹	1	Diaphragm Assembly (Nitrile)
6 ²⁰	1	Diaphragm Assembly (Nitrile)
6 ²¹	1	Diaphragm Assembly (Nitrile)
6 ²²	1	Diaphragm Assembly (Nitrile)
6 ²³	1	Diaphragm Assembly (Nitrile)
6 ²⁴	1	Diaphragm Assembly (Nitrile)

1	For 19513- 11	Service Kit Only. (1:1 Ratio)
2	For 19513- 12	Service Kit Only. (1:2 Ratio)
3	For 19513-13	Service Kit Only. (1:3 Ratio)
4	For 19513-21	Service Kit Only. (2:1 Ratio)
5	For 19513-31	Service Kit Only. (3:1 Ratio)
6	For 19513-11A	Service Kit Only. (1:1 Ratio)
7	For 19513-11AI	Service Kit Only. (1:1 Ratio)
8	For 19513-11I	Service Kit Only. (1:1 Ratio)
9	For 19513-11J	Service Kit Only. (1:1 Ratio)
10	For 19513-12J	Service Kit Only. (1:2 Ratio)
11	For 19513-21J	Service Kit Only. (2:1 Ratio)
12	For 19513-11JI	Service Kit Only. (1:1 Ratio)
13	For 19513-11JN	Service Kit Only. (1:1 Ratio)
14	For 19513-12JN	Service Kit Only. (1:2 Ratio)
15	For 19513-13JN	Service Kit Only. (1:3 Ratio)
16	For 19513-21JN	Service Kit Only. (2:1 Ratio)
17	For 19513-31JN	Service Kit Only. (3:1 Ratio)
18	For 19513-11JNI	Service Kit Only. (1:1 Ratio)
19	For 19513-11N	Service Kit Only. (1:1 Ratio)
20	For 19513-12N	Service Kit Only. (1:2 Ratio)
21	For 19513-13N	Service Kit Only. (1:3 Ratio)
22	For 19513-21N	Service Kit Only. (2:1 Ratio)
23	For 19513-31N	Service Kit Only. (3:1 Ratio)
24	For 19513-11NI	Service Kit Only. (1:1 Ratio)

TROUBLE-SHOOTING

Table 4. Trouble-Shooting	
Problem	Solution (check)
Leakage	Check Body Screw tightness. Check Diaphragm.
High Bleed	Check Relief Pintle and Relief Seat for damage or contamination.

LEGAL NOTICE:

The information set forth in the foregoing Installation, Operation and Maintenance Instructions shall not be modified or amended in any respect without prior written consent of Fairchild Industrial Products Company. In addition, the information set forth herein shall be furnished with each product sold incorporating Fairchild's unit as a component thereof.



**ISO 9001:2000
Certified**

ISO 9001:2000
FM NO. 25571

